



## Model 450 Series II ARTICULATING BOOMLIFTS

### Features

**Articulating Jib** (450AJ only) 4 ft 1 in. (1.24 m)  
**Platform** Side Entry 30 x 72 in. (0.76 x 1.83 m)  
**Inward Swinging Self-Closing Gate**  
**180 Degree Hydraulic Platform Rotator**  
**Platform Console Machine Status Light Panel\***  
**110V-AC Receptacle in the Platform**  
**5 Degree Tilt Alarm/Indicator Light**  
**Rim Protector Lug Tread Tires**  
**Swing Out Engine Module**  
**Gull-wing Turntable Hoods**  
**12V-DC Auxiliary Power**  
**Hourmeter**  
**Hydrostatic Drive**  
**Proportional Controls**  
**Control ADE® System**  
**Lifting/Tie Down Lugs**  
**Horn**  
**Oscillating Axle**  
**Cast Aluminum Control Box**  
**Operator Tool Tray**  
**Motion Alarm**

\* Provides indicator lights at platform control console for system distress, low fuel, 5 degree tilt light, and foot switch status

### Accessories & Options

**30 x 60 in. (0.76 x 1.52 m) Platform**  
**Mesh to Top Rail — Bolt-on Aluminum**  
**1/2 in. Air Line to Platform**  
**Soft Touch System**  
**12 x 16.5 Lug Tread Tires**  
**Foam-Filled Tires**  
**Non-Marking Tires**  
**Exhaust Purifier Muffler (Deutz)**  
**2500W Generator**  
**Flashing Amber Beacon**  
**43.5 lb (19.73 kg) Propane Tank**  
**Cold Weather Kit1**  
**Hostile Environment Kit2**  
**Arctic Package3**  
**Semi-Trak**  
**Light Package**  
**Platform Worklights**

#### Accessories

**SkyPower® Package** — Includes 7500W generator, power cable to platform, and 1/2 in. air line to platform.

**SkyWelder® Package** — Includes SkyPower® Package, 280-Amp Miller® welder in the platform, leads, clamp and stinger.

**SkyCutter® Package** — Includes SkyPower® and Miller Plasma Cutter mounted in platform.

1. Includes battery blanket, hydraulic tank heater, block heater (Ford and CAT), glow plugs (Deutz and CAT)
2. Includes boom wipers, cylinder bellows and console cover.
3. Includes arctic hydraulic hoses (drive and steer only) and main boom cable, arctic hydraulic oil, extreme cold engine oil, anti-freeze (CAT only), fuel conditioner, engine block heater, battery blanket, glow plugs, hydraulic tank heater, and oversized footswitch.

Note: Some options may increase lead time, and some option combinations may not be available.



### Increased Productivity

- Larger work envelope on jib and non-jib models
- Standard articulating jib on the 450AJ increases access in confined spaces
- Improved rough terrain capabilities with 45% gradeability
- Industry leading duty cycles

### Enhanced Control

- Exclusive Control ADE® (Advanced Design Electronics) system for better performance with improved serviceability
- Common control system to other JLG combustion-powered boom lifts for reduced training
- Provides better fuel efficiency to lower costs and increase uptime

### Improved Maintainability

- Enhanced electrical and hydraulic systems minimize wiring and hoses, reducing wear and maintenance
- Control ADE system minimizes the number of wires and connections



# Model 450 Series II

## ARTICULATING BOOMLIFTS

### Specifications

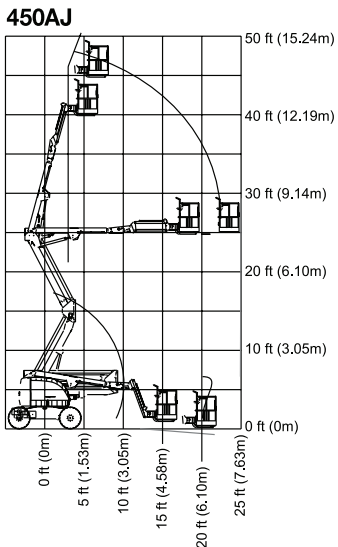
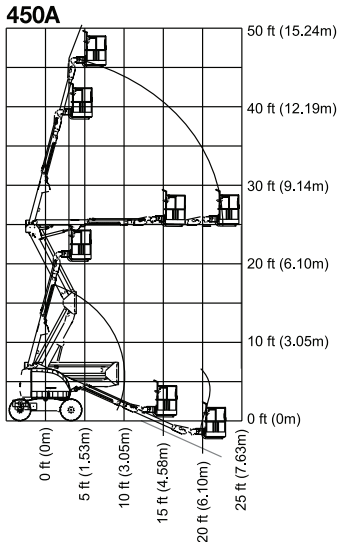

#### Reach

Platform Height	45 ft (13.72 m)
Horizontal Outreach	24 ft 6 in. (7.47 m)
Up and Over Height	25 ft 2 in. (7.67 m)
Swing	360 Degrees Non-Continuous
Platform Capacity	
Unrestricted	500 lb (227 kg)
Platform Rotator	180 Degrees Hydraulic
Jib (450AJ Only)	4 ft 1 in. (1.24 m)
Range of Articulation	145 Degrees (+78, -67)

#### Dimensions

A. Platform Size	30 x 72 in. (0.76 x 1.83 m)
B. Overall Width	6 ft 10 in. (2.08 m)
C. Tailswing (working condition)	Zero
D. Stowed Height	7 ft 5 in. (2.26 m)
E. Stowed Length	21 ft 5 in. (6.53 m)
F. Wheelbase	6 ft 6 in. (1.98 m)
G. Ground Clearance	14 in. (36 cm)

#### Weight

450A	14,500 lb (6,577 kg)
450AJ	16,500 lb (7,484 kg)

#### Max. Ground Bearing Pressure

450A	35 psi (2.46 kg/cm <sup>2</sup> )
450AJ	36 psi (2.53 kg/cm <sup>2</sup> )

#### Chassis

Drive Speed 2WD	3.5 mph (5.6 kmph)
Drive Speed 4WD	4.5 mph (7.2 kmph)
Gradeability 2WD	30%
Gradeability 4WD	45%
Tires	33/1550 x 16.5 Superwide
Axle Oscillation	8 in. (20.3 cm)
Turning Radius (Inside/Outside)	5 ft 8 in./14 ft (1.73 m/4.27 m)

#### Power Source

Dual Fuel Engine	
GM Vortec 3000 MPFI	82 hp (61 kW)
Diesel Engine	
Deutz F3M1011	47 hp (35 kW)
Diesel Engine	
Caterpillar C2.2	50 hp (37.2 kW)
Fuel Tank Capacity	16.5 gal. (62.5 L)
Hydraulic Reservoir	30 gal. (113.6 L)
Auxiliary Power	12V DC

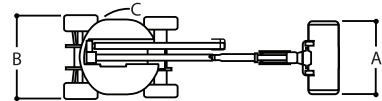
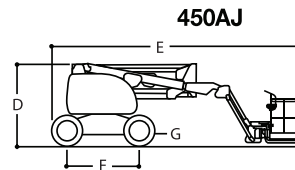
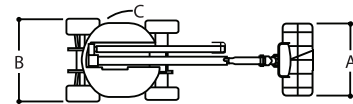
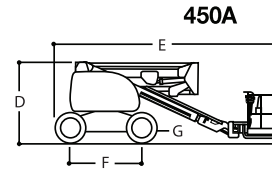

### The JLG "2 & 5" Warranty

JLG Industries, Inc. backs our 450 Series II boom lifts with our exclusive "2 & 5" Warranty. We provide coverage for two (2) full years, and cover all specified major structural components for five (5) years. These machines meet or exceed applicable OSHA Regulations in 29 CFR 1910.67, 29 CFR 1926.453, ANSI A92.5-2006 and CSA standard B354.4-02 as originally manufactured for intended applications. We reserve the right to make price, specification, and/or equipment changes without prior notification.