

A46JE/A46JRT

ARTICULATED BOOM LIFTS

UP2IT ACCESS
HIRE
www.up2it.co.nz



- Class-leading articulated boom lifts
- Choose from electric or rough terrain diesel models
- Highly manoeuvrable with tight turning radius
- Superb working envelope with zero tailswing
- Robust, reliable and easy to operate

snorkel
www.up2it.co.nz

ARTICULATED BOOM LIFTS

A46JE/A46JRT

DIMENSIONS	A46JE	A46JRT
Max. working height	16.1m	16.3m
Max. platform height	14.1m	14.3m
Max. working outreach	7.4m	7.4m
Platform size	1.0 x 1.85m	1.0 x 1.85m
Chassis width (A)	1.7m	2.1m
Overall length (B)	5.6m	5.6m
Stowed height (C)	2.0m	2.1m
Ground clearance	152mm	330mm

PERFORMANCE	A46JE	A46JRT
Platform capacity (SWL)	227kg	227kg
Max. drive height	14.1m	14.3m
Max. drive speed (stowed)	5.1km/h	7.2km/h
Max. drive speed (elevated)	1.3km/h	1.2km/h
Jib length	1.5m	1.5m
Jib arc	140°	140°
Platform rotation	160°	160°
Turret rotation	360° non-continuous	360° non-continuous
Raise/lower time	101/108 seconds	120/112 seconds
Gradeability	30%	45%
Inside turning radius	0.60m	0.80m
Outside turning radius	3.0m	3.1m
Tyres	Non-marking IN240/55D	High grip 355/55D625NHS 17.5
Controls	proportional	proportional
Drive system	2 wheel drive	4 wheel drive

POWER	A46JE	A46JRT
Power source	8 x 6V 360Ah batteries	Kubota V1505T Diesel

WEIGHT	A46JE	A46JRT
Gross weight	6,486kg	6,622kg

WORKING ENVELOPE

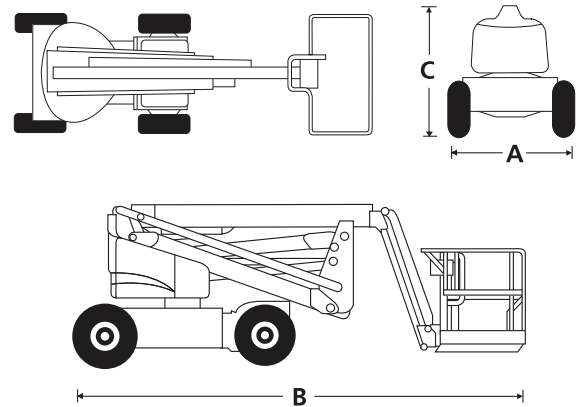
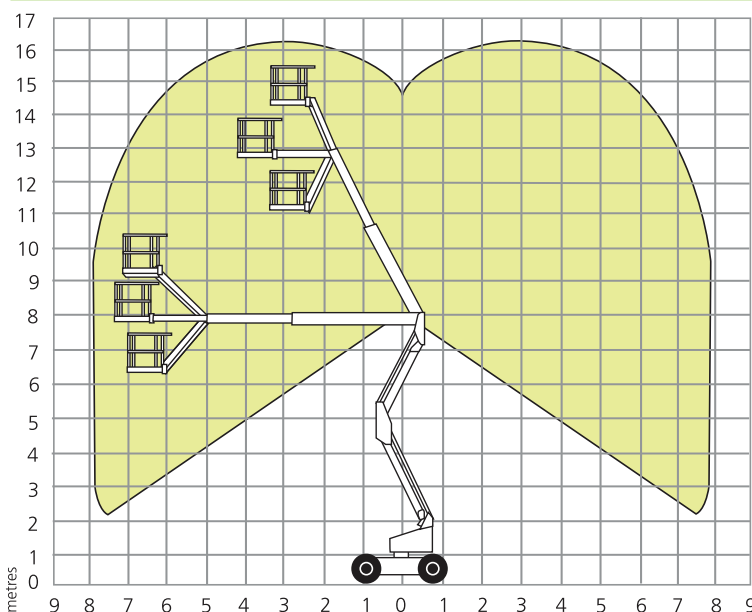

STANDARD FEATURES

- Multi-function, variable speed platform controls
- Oscillating front axle (A46JRT)
- Proportional controls
- Power line to platform (no sockets)
- Zero tailswing
- Hour meter
- Battery charge indicator (A46JE)
- Wide rough terrain tyres, foam-filled (A46JRT)
- CE approved

OPTIONS

- Special paint colours
- AC generator 240/2kW (A46JRT)
- Amber beacon
- Drive motion alarm
- Airline to platform (A46JRT)
- Cold weather package (A46JRT)
- Light package (A46JRT)
- Extreme environment package (A46JRT)
- Aircraft package
- Deluxe aircraft package
- Diesel exhaust scrubber (A46JRT)
- Extreme cold weather package (A46JRT)

UP2IT ACCESS HIRE
www.up2it.co.nz

UP2IT Access Hire
90 Cryers Road, East Tamaki, Auckland 2163

FREEPHONE: 0800 830 530 **PHONE:** (09) 274 5944
ON CALL: 0272 830 535 **FAX:** (09) 274 5662

EMAIL: sales@up2it.co.nz